

DISCLAIMER: Emtion Pty Ltd, Trading as Microtec Engineering, do not take any responsibility for any damage caused installing this product

MICROTEC ENGINEERING

EXTERNAL WARNING LIGHT INSTALLATION INSTRUCTIONS

TADANO AML M1/M2 (TL)

ESTIMATED TIME OF INSTALLATION: 4 HOURS

SUPPLIED PARTS:

- 1x Activation box
- 5 mtrs 7 core cable
- 1x eye crimp
- 1x piggy-back female crimp
- 1x Bullet crimp terminal (blue)
 - Solder
 - Heatshrink
- 2x Self drilling screws
- 1x Cable grommet
 - Cable Ties
- 10x Ferrule crimps
- External warning light

TADANO AML M1/M2 LIGHT INSTALLATION

Read all instructions before commencing

PRE-INSTALLATION CHECKS

1. Set up machine on full outriggers and raise the boom so there are no errors or buzzers active. Set-up computer for main hook and full outriggers.
2. Raise any hook to an ATB alarm situation. Check that the crane motions winch up, luff down, and tele out functions are cut off. Check that the “safe” crane motions winch down, tele in and luff up are operable.
3. Whilst still in alarm condition, switch the ATB over-ride and verify that the unsafe functions are now operable.
 - *note: be careful not to overwind hook*
4. Repeat steps 1-3 with the other hook.
5. Locate the button on the AML screen on the bottom right hand corner with a symbol of an exclamation mark. Whilst holding this button on, check that all unsafe motions (Luff down, winch up, Tele out) are in-operable and safe functions (luff up, winch down, tele in) are operable.
6. Then switch the AML over-ride and confirm all unsafe functions are operational.
 - *Beware: Autostop functions will not operate during over-ride.*
7. ride.
8. When the exclamation mark button is pressed also verify that the buzzer is sounding.
 - Should any of these tests fail call Microtec for service

INSTALLATION OF INPUTS AND POWER SUPPLY

PREINSTALLATION PREPARATION

1. Isolate batteries during installation with isolator switch.
2. Remove seat in cabin
3. Remove side panel located on the left hand side of seat to expose connections to fuse box, radio etc.
4. Remove the panel which holds the ATB over-ride switch.
5. Fit the activation box in a clear area behind this panel. If no place behind panel is suitable, it can be fitted externally. It is preferable for installation that this unit is kept near this area though.

CONNECTIONS TO TADANO (TL) AML M1/M2

SWITCH NO.	SWITCH POSITION
1	On
2	On
3	Off
4	Off
5	Off
6	On

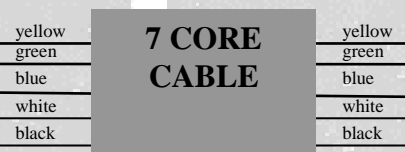
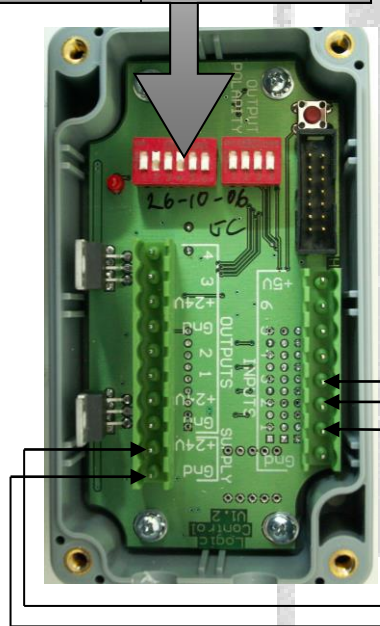

❖ Unused from 7 core cable may be cut off from the loom.

Use ferrule crimps provided to make the connections to the activation box. You may also need to shorten the length of the ferrules so the lid can close easily.

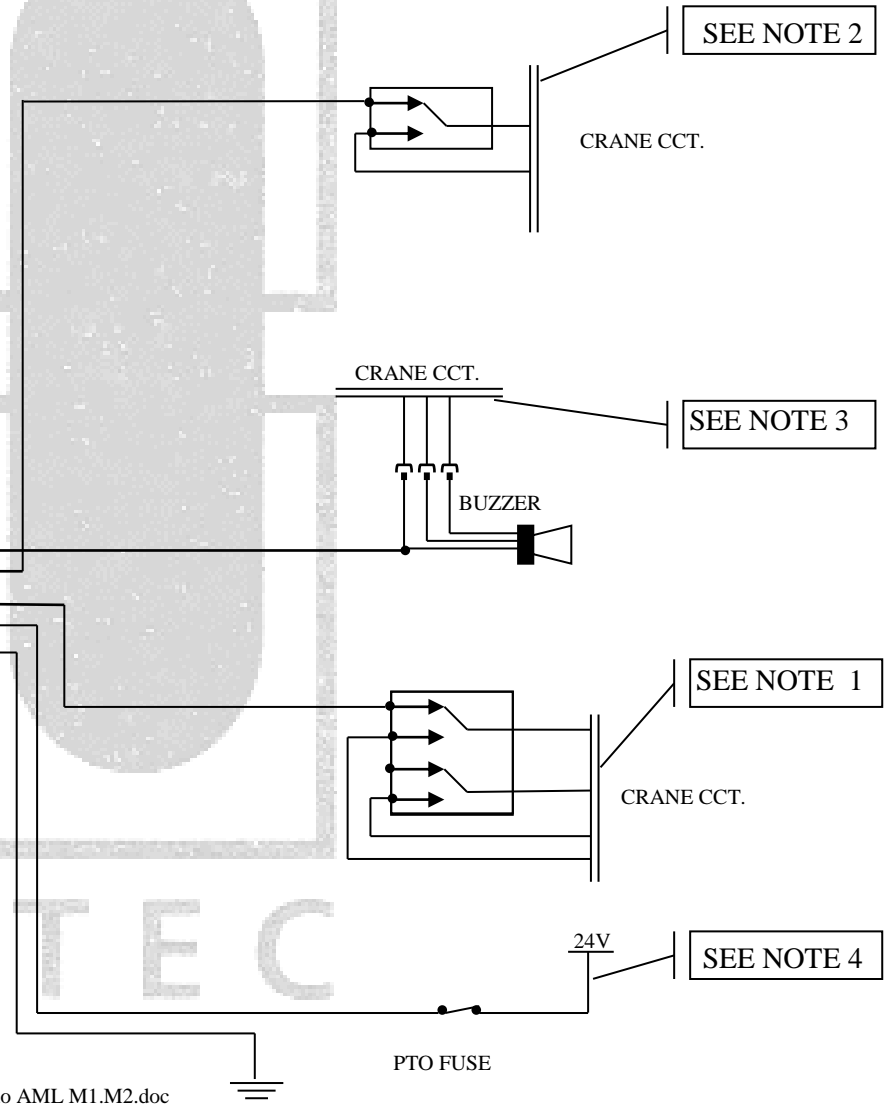

NOTES

- 1
- Inspect the contacts of the ATB switch and confirm that one contact is free and the others are connected to various ccts as shown below. Use the blue wire to connect to this terminal..

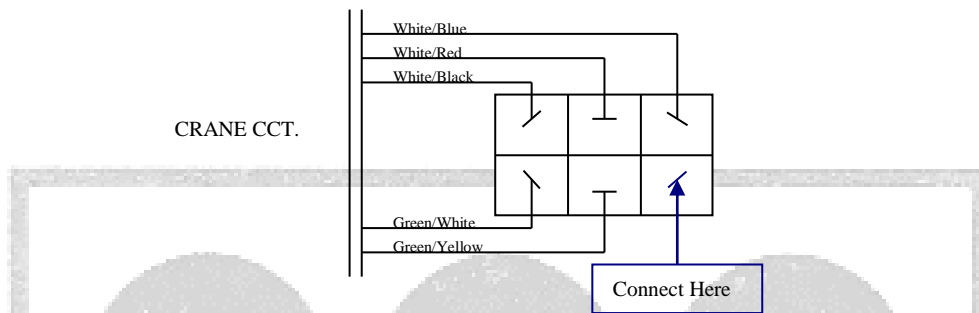

- 2
- Confirm that the O/R switch is a single pole switch and the wire colours correspond to diagram below.
 - Connect the green wire to the normally closed contact.

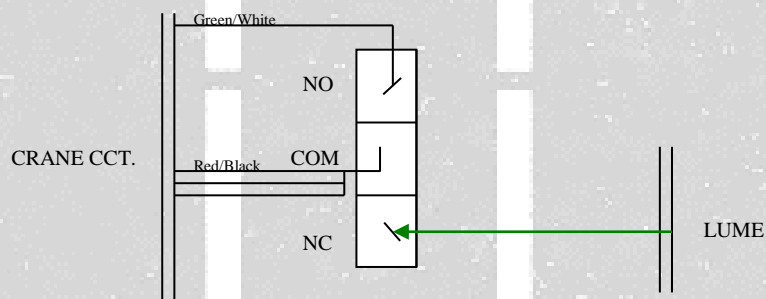

If the over-ride is a key-switch or another configuration, please contact Microtec Engineering

- 3
- Locate the connections to the buzzer at the bottom right hand side of cavity (behind the side panel taken off in the preinstallation preparation).
 - Confirm that the yellow/green wire shown in diagram below is present.
 - Insert the yellow wire from the loom and the original wire that was connected to the yellow/green wire into the bullet crimp provided (shown in the diagram below).

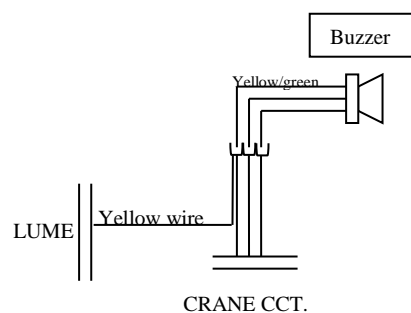

- 4
- Locate the AML fuse. This should be written on the fuse box lid.
 - Connect the white wire to the ‘fused’ side of the AML fuse. Use the piggy-back female blade terminal supplied.
 - To find the ‘fused’ side:
 - ⇒ remove the AML fuse and then turn PTO on
 - ⇒ measure either side of the fuse holder to see which side has +24V
 - ⇒ Turn the PTO switch off
 - ⇒ Replace the fuse. The fused side is the end that didn’t have +24V when fuse was removed
 - Locate a suitable earth point. On the metal back plate which the relays are mounted on, there should be a common earth point.
 - Connect the eye terminal to the black wire and fix to the common earth point.

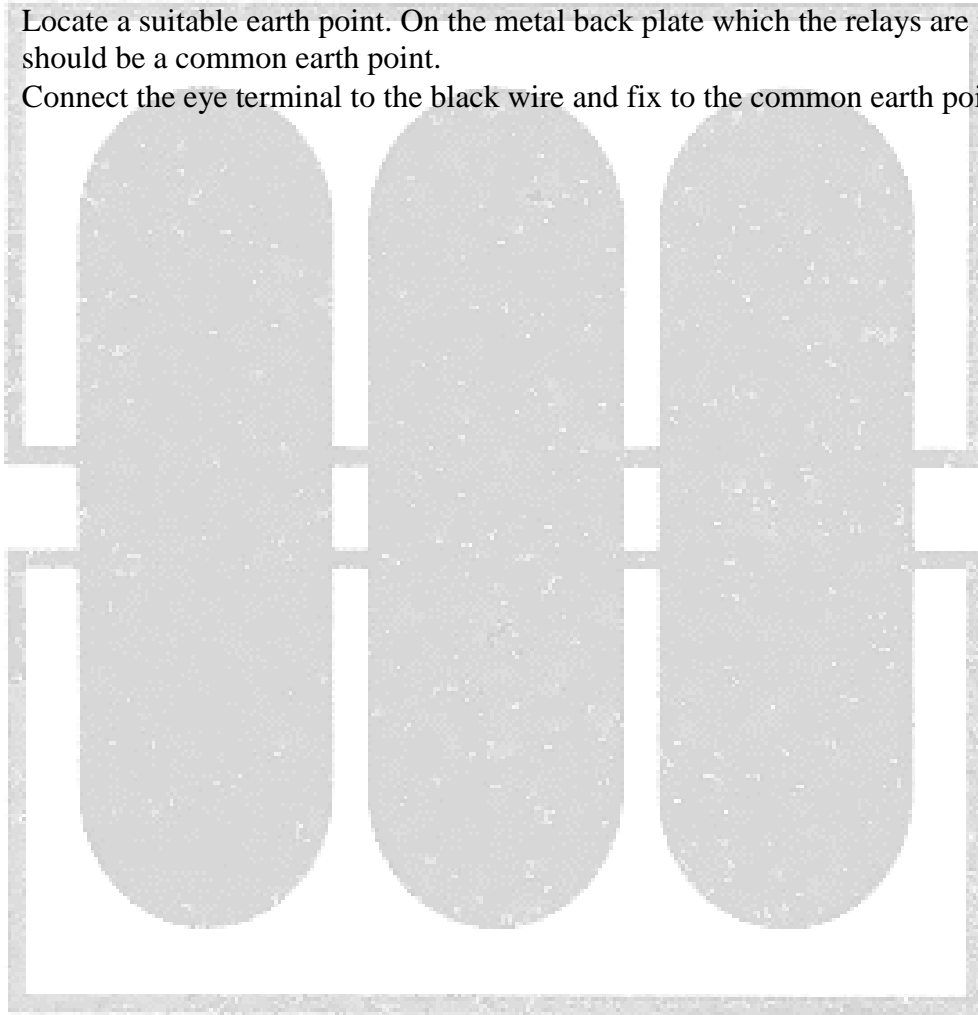

M I C R O T E C